

# Packing internally assessed samples

**Samples** (+ relevant forms from the samples database and a separate copy of your internally assessed marks)

**Subject-specific  
bar-coded label**

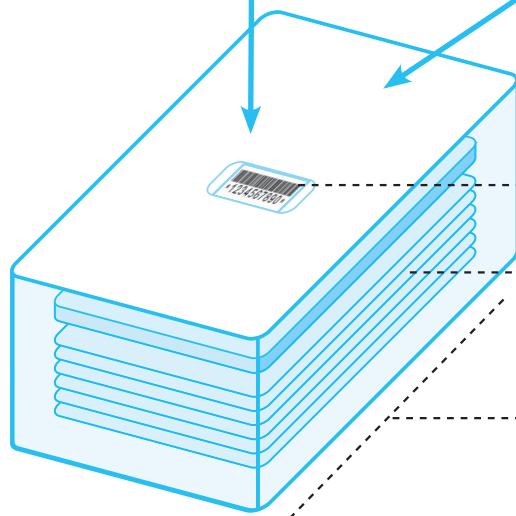
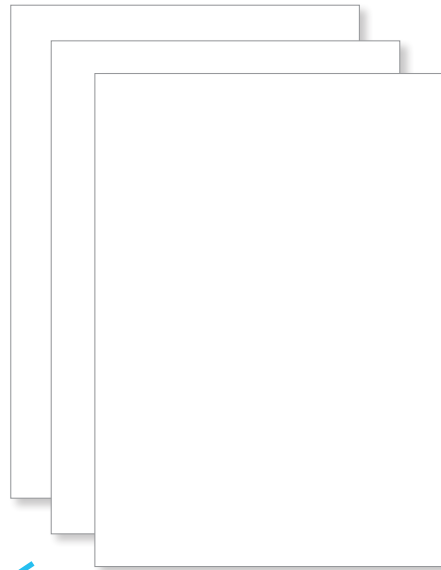
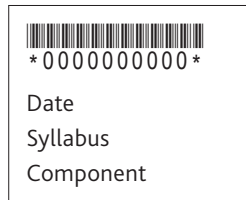

Bar-coded label

Samples with coursework  
identification labels attached

Individual packet  
(not supplied by us)

## Important information

- Include anything else as mentioned in the samples database [www.cambridgeinternational.org/samples](http://www.cambridgeinternational.org/samples)
- Include a copy of your internally assessed marks
- Do not send your samples without outer packaging
- Despatch your packages following our guidance.

# Despatching internally assessed samples

Samples packets

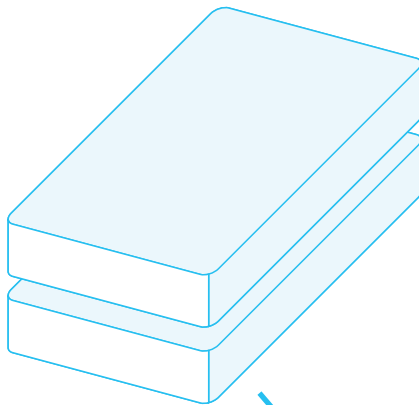

Coursework address label

Centre Name .....	<b>Cambridge Assessment DC10</b> Hill Farm Road Whittleford Cambridge CB22 4FZ England
Centre Number .....	
Syllabus Title .....	
Component Code .....	
Have you enclosed (tick as appropriate)	
<input type="checkbox"/> MSI (Moderator's Copy) or print-out of the marks file?	UR1003
<input type="checkbox"/> Individual Candidate Record Cards and Coursework Assessment Summary Forms?	
<input type="checkbox"/> Coursework samples, labelled if appropriate?	
<input type="checkbox"/> CDs, DVDs or tapes, if appropriate, clearly labelled?	CONTENTS: EDUCATIONAL EXAMINATION MATERIALS

Use the despatch label provided

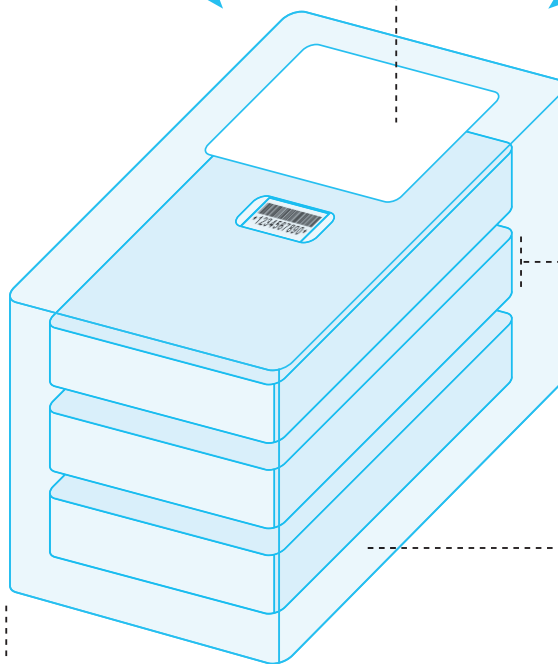

Do not send samples without any outer packaging

Make sure your outer packaging is secure and that the total weight is no more than 15kg.

Make sure corners are secure.  
Use extra packaging if necessary.

## Important information

- Do not send multiple components for the same syllabus in one package
- Once you have packed your samples contact a reputable courier who provides a tracking number.